

Data Sheet

Customer:

Product: Automotive Grade High Voltage Thick Film Chip Resistor –
HVR..A Series

Size: 0402/0603/0805/1206/2010/2512

Issued Date: 08-Jul-24

Edition: REV.A4



VIKING TECH CORPORATION
光頡科技股份有限公司
No.70 Guangfu N. Rd., Hukou
Township, Hsinchu County 303,
Taiwan

TEL:886-3-5972931
FAX:886-3-5972935•886-3-5973494
E-mail:sales@viking.com.tw

VIKING TECH CORPORATION KAOHSIUNG BRANCH
光頡科技股份有限公司高雄分公司
No.248-3, Sin-Sheng Rd., Cian-Jhen Dist., Kaohsiung,
806, Taiwan

TEL:886-7-8217999
FAX:886-7-8228229
E-mail:sales@viking.com.tw

VIKING ELECTRONICS (WUXI) CO., LTD.
光頡電子(無錫)有限公司
No.22 Xixia Road, Machinery & Industry Park,
National Hi-Tech Industrial Development Zone
of Wuxi, Wuxi, Jiangsu Province, China
Zip Code:214028
TEL:86-510-85203339
FAX:86-510-85203667•86-510-85203977
E-mail:china@viking.com.tw

Produced by (QC)	Checked (QC)	Approved by (QC)	Prepared by (Sales)	Accepted by (Customer)
08-Jul-24	08-Jul-24	08-Jul-24		
Alice Hsiao	Susan Huang	Susan Huang		

Automotive Grade High Voltage Thick Film Chip Resistor



Scope

- This specification applies to all sizes of rectangular-type fixed chip resistors with Ruthenium-base as material.

Features

- Highly reliable multilayer electrode construction
- Higher component and equipment reliability
- Excellent performance at high voltage
- Reduced size of final equipment
- Special construction to prevent sulfuration in a sulfur containing environment
- AEC-Q200 Qualified
- 100% CCD inspection

Construction

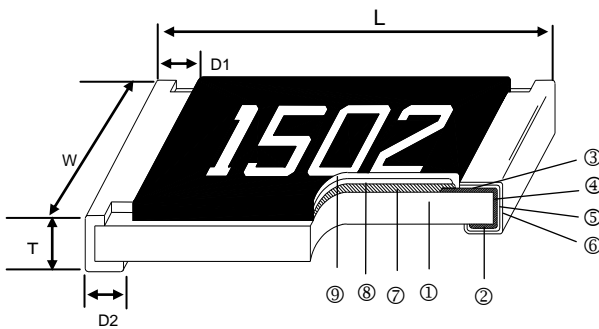

Applications

- Inverter
- Outdoor Equipments
- Converter
- High Pulse Equipment

① Alumina Substrate	④ Edge Electrode	⑦ Resistor Layer
② Bottom Electrode	⑤ Barrier Layer	⑧ Primary Overcoat
③ Top Electrode	⑥ External Electrode	⑨ Secondary Overcoat

Dimensions

Type	Size (Inch)	L (mm)	W (mm)	T (mm)	D1 (mm)	D2 (mm)	Weight (g) (1000pcs)
HVR02	0402	1.00±0.05	0.50±0.05	0.35±0.05	0.20±0.10	0.20±0.10	0.620
HVR03	0603	1.60±0.10	0.80±0.10	0.45±0.10	0.30±0.20	0.30±0.20	2.042
HVR05	0805	2.00±0.10	1.25±0.10	0.50±0.10	0.35±0.20	0.40±0.20	4.368
HVR06	1206	3.10±0.10	1.55±0.10	0.55±0.10	0.50±0.25	0.50±0.20	8.947
HVR0A	2010	5.00±0.10	2.50±0.15	0.55±0.10	0.60±0.25	0.50±0.20	24.241
HVR12	2512	6.35±0.10	3.10±0.15	0.55±0.10	0.60±0.25	0.50±0.20	39.448

Part Numbering

HVR	03	F	T	E	X	1003	A
Product Type	Dimensions	Resistance Tolerance	Packaging Code	TCR (PPM/°C)	Power Rating	Resistance	Marking
	02: 0402 03: 0603 05: 0805 06: 1206 0A: 2010 12: 2512	F: ±1% J: ±5%	T: 7" Taping Reel V: 10" Taping Reel W: 13" Taping Reel	E: ±100 F: ±200 H: ±400	Y: 1/16W X: 1/10W W: 1/8W V: 1/4W U: 1/2W T: 1W	1003: 100KΩ 1004: 1MΩ 1005: 10MΩ	A: Automotive Grade NA: Automotive Grade & No Marking

Recommend Land Pattern

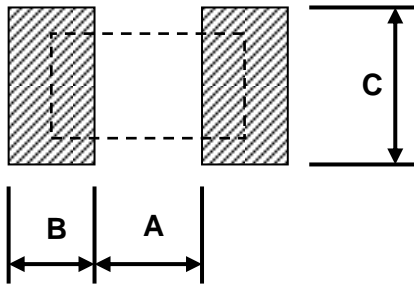

Type	A (mm)	B (mm)	C (mm)
HVR02	0.50	0.45	0.60
HVR03	0.90	0.60	0.90
HVR05	1.20	0.70	1.30
HVR06	2.00	0.90	1.60
HVR0A	3.80	0.90	2.80
HVR12	4.90	1.60	3.50

Derating Curve

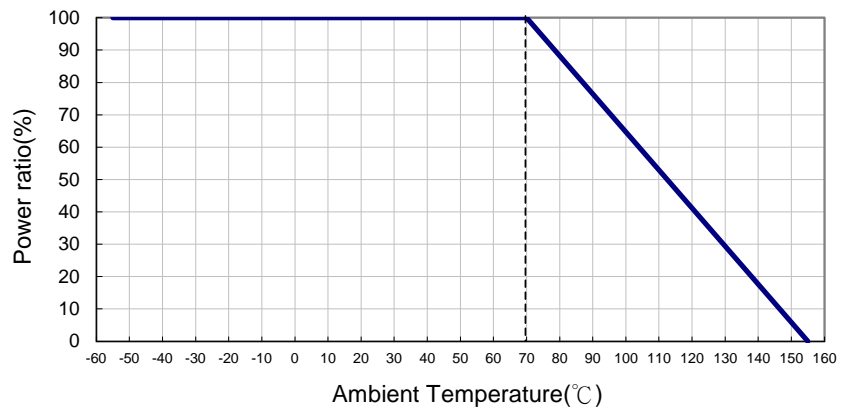

Soldering Condition (Ref. IPC/JEDEC J-STD-020 & J-STD-002)

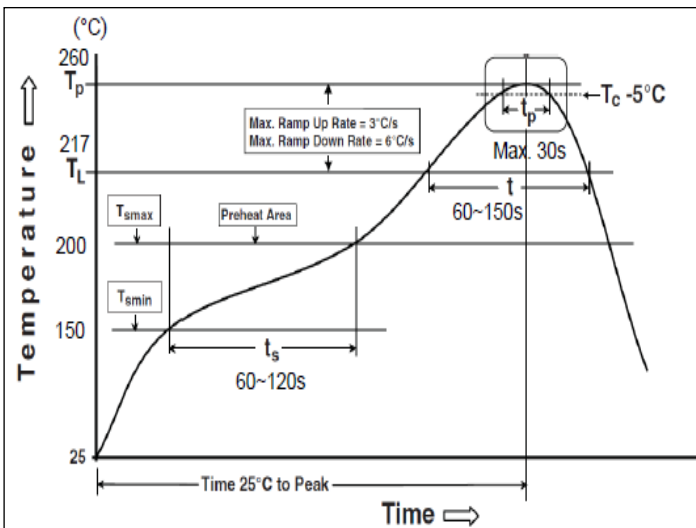

Reflow Profiles	
Profile Feature	Pb-Free Assembly
Preheat	
Min. Temperature (T _{smin})	150 °C
Max Temperature (T _{smax})	200 °C
Preheating time (t _s) from (T _{smin} to T _{smax})	60-120 seconds
Ramp-up rate (T _L to T _p)	3 °C/second max.
Liquidous temperature (T _L)	217 °C
Time (t _L) maintained above T _L	60-150 seconds
Min. Peak temperature (T _{p min})	235°C
Max. Peak temperature (T _{p max})	260°C
Time (t _p) within 5 °C of the specified classification temperature (T _c)	30 seconds max.
Ramp-down rate (T _p to T _L)	6 °C/second max.
Time 25 °C to peak temperature	8 minutes max.

Standard Electrical Specifications

Type	Item	Power Rating at 70°C	Operating Temp. Range	Max. Operating Voltage	Max. Overload Voltage	Resistance Range		TCR (PPM/°C)
						±1%(E24、E96)	±5%(E24)	
HVR02 (0402)	1/16W		-55 ~ +155°C	100V	200V	39KΩ - 1MΩ		±100
						1.02MΩ - 10MΩ	1.1MΩ - 20MΩ	±200
						-	22MΩ - 100MΩ	±400
HVR03 (0603)	1/10W		-55 ~ +155°C	200V	400V	56KΩ - 1MΩ		±100
						1.02MΩ - 10MΩ	1.1MΩ - 20MΩ	±200
						-	22MΩ - 100MΩ	±400
HVR05 (0805)	1/8W		-55 ~ +155°C	400V	800V	100KΩ - 1MΩ		±100
						1.02MΩ - 10MΩ	1.1MΩ - 20MΩ	±200
						-	22MΩ - 100MΩ	±400
HVR06 (1206)	1/4W		-55 ~ +155°C	500V	1000V	100KΩ - 1MΩ		±100
						1.02MΩ - 10MΩ	1.1MΩ - 20MΩ	±200
						-	22MΩ - 100MΩ	±400
HVR0A (2010)	1/2W		-55 ~ +155°C	2000V	3000V	51KΩ - 1MΩ		±100
						1.02MΩ - 20MΩ	1.1MΩ - 20MΩ	±200
						-	22MΩ - 100MΩ	±400
HVR12 (2512)	1W		-55 ~ +155°C	3000V	4000V	30KΩ - 1MΩ		±100
						1.02MΩ - 20MΩ	1.1MΩ - 20MΩ	±200
						-	22MΩ - 100MΩ	±400

Operating Voltage= $\sqrt{P \cdot R}$ or Max. Operating Voltage listed above, whichever is lower.

Overload Voltage= $2.5 \cdot \sqrt{P \cdot R}$ or Max. Overload Voltage listed above, whichever is lower.

■ Viking is capable of manufacturing the optional spec based on customer's requirement.

Environmental Characteristics

Item	Requirement		Test Method
	±1%	±5%	
Temperature Coefficient of Resistance (T.C.R.)	As Spec.		JIS-C-5201-1 4.8 IEC-60115-1 4.8 At 25°C/-55°C and 25°C/+125°C, 25°C is the reference temperature
Short Time Overload	±(1.0%+0.05Ω)	±(2.0%+0.05Ω)	JIS-C-5201-1 4.13 IEC-60115-1 4.13 RCWV*2.5 or Max. Overload Voltage whichever is lower for 5 seconds
Insulation Resistance	≥10G		JIS-C-5201-1 4.6 IEC-60115-1 4.6 Max. Overload Voltage for 1 minute
Operational Life	±(2.0%+0.05Ω)	±(3.0%+0.10Ω)	MIL-STD-202 Method 108 Condition D Steady State TA=125°C at derated power. Measurement at 24±4 hours after test conclusion.
Biased Humidity	±(2.0%+0.05Ω)	±(3.0%+0.10Ω)	MIL-STD-202 Method 103 1000 hrs 85°C/85%RH 10% of operating power (≤ 100 V)

Item	Requirement		Test Method
	±1%	±5%	
High Temperature Exposure	±(1.0%+0.05Ω)	±(1.5%+0.10Ω)	MIL-STD-202 Method 108 at +155°C for 1000 hrs
Board Flex	±(1.0%+0.05Ω)	±(1.0%+0.05Ω)	AEC-Q200-005 Bending once for 60 seconds 2010, 2512 sizes: 2mm Other sizes: 3mm
Solderability	95% min. coverage		JIS-C-5201-1 4.17 IEC-60115-1 4.17 245±5°C for 3 seconds
Resistance to Soldering Heat	±(0.5%+0.05Ω)	±(1.0%+0.05Ω)	JIS-C-5201-1 4.18 IEC-60115-1 4.18 260±5°C for 10 seconds
Voltage Proof	No breakdown or flashover		JIS-C-5201-1 4.7 IEC-60115-1 4.7 HVR02: 150V for 1 minute HVR03: 300V for 1 minute HVR05/HVR06/HVR0A/HVR12: 500V for 1 minute
Leaching	Individual leaching area ≤ 5% Total leaching area ≤ 10%		JIS-C-5201-1 4.18 IEC-60068-2-58 8.2.1 260±5°C for 30 seconds
Temperature Cycling	±(1.0%+0.05Ω)		JESD22 Method JA-104 -55°C to +125°C, 1000 cycles
Mechanical Shock	±(1.0%+0.05Ω)		MIL-STD-202 Method 213 Wave Form: Tolerance for half sine shock pulse. Peak value is 100g's. Normal duration (D) is 6.
Vibration	±(1.0%+0.05Ω)		MIL-STD-202 Method 204 5 g's for 20 min., 12 cycles each of 3 orientations, 10-2000 Hz
ESD	±(3%+0.05Ω)		AEC-Q200-002 Human body model 0402/0603: 1KV 0805 and above: 2KV
Resistance to Solvents	No visible damage on appearance and marking.		MIL-STD-202 Method 215 Add Aqueous wash chemical - OKEM Clean or equivalent. Do not use banned solvents.
Terminal Strength	No broken		AEC-Q200-006 Force of 1.8kg for 60 seconds.
Flammability	No ignition of the tissue paper or scorching or the pinewood board		UL-94 V-0 or V-1 are acceptable. Electrical test not required.
Sulfur Test	△R±1%	△R±5%	EIA-977 (Condition A) 60±2°C, no power rating for 500 hrs.

RCWV(Rated Continuous Working Voltage)= $\sqrt{P \cdot R}$ or Max. Operating Voltage whichever is lower.

■ **Storage Temperature: 15~28°C; Humidity < 80%RH**

■ **Shelf Life: 2 years from production date.**

Embossed Plastic Tape Specifications

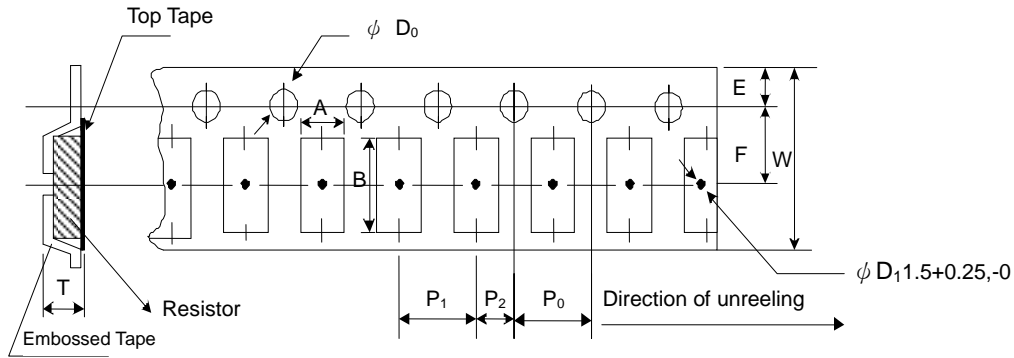

Type	A (mm)	B (mm)	W (mm)	E (mm)	F (mm)	P ₀ (mm)	P ₁ (mm)	P ₂ (mm)	ΦD ₀ (mm)	T (mm)
HVR0A	2.8±0.10	5.40±0.20	12.0±0.30	1.75±0.10	5.5±0.05	4.00±0.10	4.00±0.10	2.00±0.05	1.50+0.1, -0	1.2 ⁺⁰
HVR12	3.5±0.10	6.7±0.10	12.0±0.30	1.75±0.10	5.5±0.05	4.00±0.10	4.00±0.10	2.00±0.05	1.50+0.1, -0	1.2 ⁺⁰

■ Marking

No Marking for 0402

1% for 0805/1206/2010/2512: 4 digits marking

Example:

Resistance	49.9KΩ	100KΩ	1MΩ	4.99MΩ	10MΩ
Marking	4992	1003	1004	4994	1005

5% for 0603/0805/1206/2010/2512: 3 digits marking in E24

Example: 124=120KΩ 106=10MΩ (1st and 2nd are E24 code and 3rd code is multiplier)

E24 code	10	11	12	13	15	16	18	20	22	24	27	30	33	36	39	43	47	51	56	62	68	75	82	91
----------	----	----	----	----	----	----	----	----	----	----	----	----	----	----	----	----	----	----	----	----	----	----	----	----

1% for 0603: 3 digits marking in E96

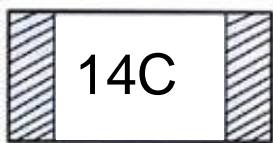

3 digits marking for Example: 75C=59KΩ 39E=2.49MΩ

■ Marking Table

Code	E96	Code	E96	Code	E96	Code	E96			
01	100	25	178	49	316	73	562			
02	102	26	182	50	324	74	576			
03	105	27	187	51	332	75	590			
04	107	28	191	52	340	76	604			
05	110	29	196	53	348	77	619			
06	113	30	200	54	357	78	634			
07	115	31	205	55	365	79	649			
08	118	32	210	56	374	80	665			
09	121	33	215	57	383	81	681			
10	124	34	221	58	392	82	698			
11	127	35	226	59	402	83	715			
12	130	36	232	60	412	84	732			
13	133	37	237	61	422	85	750			
14	137	38	243	62	432	86	768			
15	140	39	249	63	442	87	787			
16	143	40	255	64	453	88	806			
17	147	41	261	65	464	89	825			
18	150	42	267	66	475	90	845			
19	154	43	274	67	487	91	866			
20	158	44	280	68	499	92	887			
21	162	45	287	69	511	93	909			
22	165	46	294	70	523	94	931			
23	169	47	301	71	536	95	953			
24	174	48	309	72	549	96	976			
Code	A	B	C	D	E	F	X	Y		
Multiplier	10 ⁰	10 ¹	10 ²	10 ³	10 ⁴	10 ⁵	10 ⁻¹	10 ⁻²		

REVISION HISTORY

REVISION	DATE	CHANGE NOTIFICATION	DESCRIPTION
Version A	Mar 10, 2021	-	- New product release
Version A1	Nov 15, 2021	-	- Increase the shelf life description
Version A2	Feb 15, 2022	-	- Derating Curve changes the temperature range
Version A3	Jun 15, 2022	-	- Modify Soldering Condition
Version A4	Jul 08, 2024	-	- Modify the descriptions in the Features