

Data Sheet

Customer :

Product : Automotive Grade Thin Film Precision Chip Resistor
(Wide Terminal) – ARW..A Series

Size: 0612/1020/1225

Issued Date: 1-Jul-24

Edition : REV.A1



VIKING TECH CORPORATION
光韻科技股份有限公司

No.70, Guangfu N. Rad.,
Hsin Chu Industrial Park,
Hukou Hsiang, Hsin Chu Hsien,
303, Taiwan

TEL:886-3-5972931

FAX:886-3-5972935•886-3-5973494

E-mail:sales@viking.com.tw

VIKING TECH CORPORATION KAOHSIUNG BRANCH
光韻科技股份有限公司高雄分公司

No.248-3, Sin-Sheng Rd., Cian-Jhen Dist., Kaohsiung,
806, Taiwan

TEL:886-7-8217999

FAX:886-7-8228229

E-mail:sales@viking.com.tw

Viking Electronics (WUXI) CO., LTD.
光韻電子(無錫)有限公司

No.1A,(Xixia Road),Machinery & Industry Park,
National Hi-Tech Industrial Development Zone of
Wuxi, Wuxi, Jiangsu Province, China
Zip Code:214028

TEL:86-510-85203339

FAX:86-510-85203667•86-510-85203977

E-mail:wuxisales@tmtec.com.tw

Produced by (QC)	Checked (QC)	Approved by (QC)	Prepared by (Sales)	Accepted by (Customer)
1-Jul-24	1-Jul-24	1-Jul-24		
Chun	Ben Chang	Ben Chang		

Automotive Grade Thin Film Precision Chip Resistor(Wide Terminal)

■ Features

- AEC-Q200 Qualified
- Advanced thin film technology
- RoHS compliant
- Special materials, design, and processing for high sulfur applications
- Test proven immunity to humidity, moisture, and sulfur

■ Applications

- Automotive electronics
- DC motor , inverters
- Robotics , Industrial control system



■ Construction

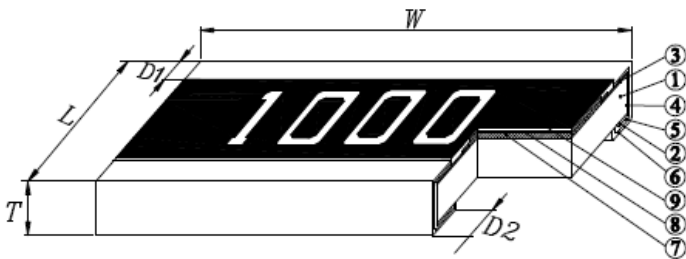

① Alumina Substrate	④ Edge Electrode	⑦ Resistor Layer
② Bottom Electrode	⑤ Barrier Layer	⑧ 1 st Overcoat
③ Top Electrode	⑥ External Electrode	⑨ 2 nd Marking

■ Dimensions

Unit: mm

Type	Size (Inch)	L	W	T	D1	D2	Weight (g) (1000pcs)
ARW62	0612	1.55±0.15	3.00±0.15	0.43±0.10	0.25±0.15	0.32±0.15	7.69
ARW20	1020	2.45±0.20	4.90±0.20	0.43±0.10	0.40±0.20	0.52±0.20	20.95
ARW25	1225	3.15±0.20	6.30±0.20	0.43±0.10	0.45±0.20	0.52±0.20	33.24

■ Part Numbering

ARW	62	B	T	C	T	1001	A
Product Type	Dimensions (LxW)	Resistance Tolerance	Packaging Code	TCR (PPM/°C)	Power Rating	Resistance	Marking Code
	62: 0612 20: 1020 25: 1225	B: ±0.1% C: ±0.25% D: ±0.5% F: ±1%	T: Taping Reel B: Bulk	C: ±25 D: ±50	T: 1.0W A: 1.5W S: 2.0W	0100: 10Ω 10R2: 10.2Ω 1000: 100Ω 1001: 1KΩ 1003: 100KΩ	A: Automotive Grade NA: No Making Automotive Grade

Derating Curve

ARW Series

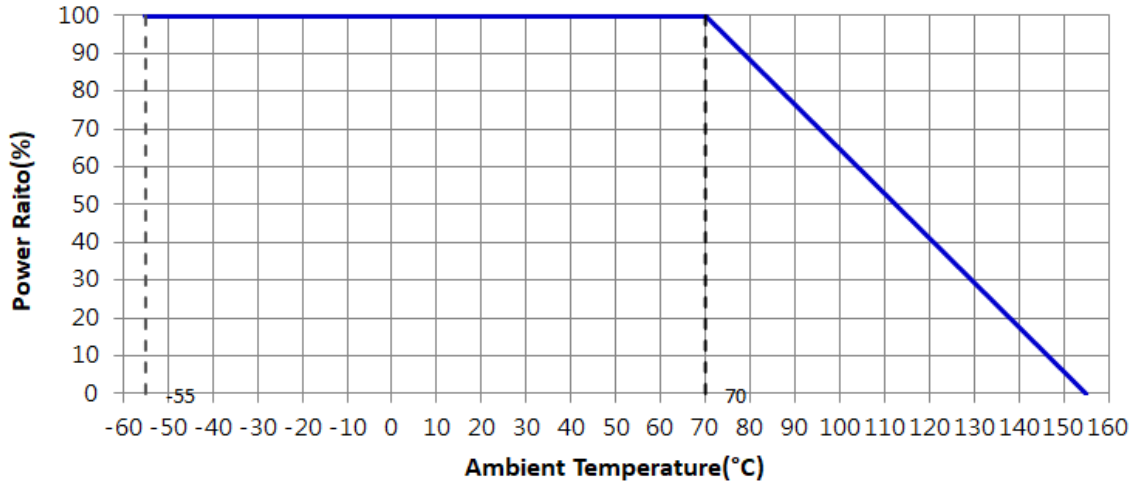

ARW Series

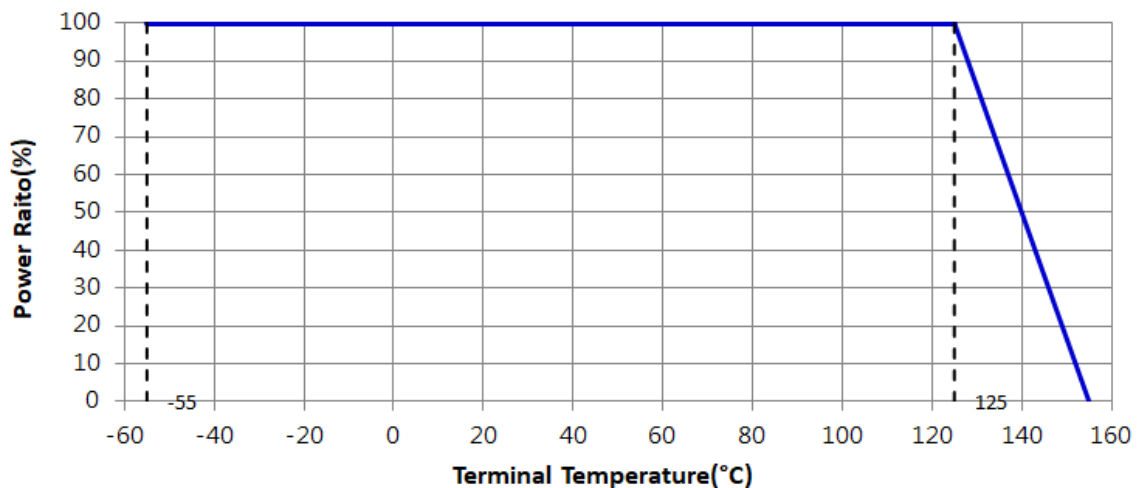

Standard Electrical Specifications

Type	Item	Power Rating at 70°C	Operating Temp. Range	Max. Operating Voltage	Max. Overload Voltage	Resistance Range				TCR (PPM/°C)
						±0.1%	±0.25%	±0.5%	±1%	
ARW62 (0612)		1.0W	-55 ~ +155°C	75V	150V	2.5Ω – 80KΩ				±25 ±50
ARW20 (1020)		1.5W	-55 ~ +155°C	100V	200V	2.5Ω – 200KΩ				±25 ±50
ARW25 (1225)		2.0W	-55 ~ +155°C	200V	400V	2.5Ω – 250KΩ				±25 ±50

Operating Voltage= $\sqrt{P \cdot R}$ or Max. operating voltage listed above, whichever is lower.
 Overload Voltage= $2.5 \cdot \sqrt{P \cdot R}$ or Max. overload voltage listed above, whichever is lower.

■ Viking is capable of manufacturing the optional spec based on customer's requirement.

■ Environmental Characteristics

Item	Requirement	Test Method
Temperature Coefficient of Resistance (T.C.R.)	As Spec.	JIS-C-5201-1 4.8 IEC-60115-1 4.8 -55°C~+125°C, 25°C is the reference temperature
Short Time Overload	$\Delta R \pm 0.1\%$	JIS-C-5201-1 4.13 RCWV*2.5 or Max. overload voltage whichever is lower for 5 seconds
Insulation Resistance	>1000 M Ω	JIS-C-5201-1 4.6 IEC-60115-1 4.6 Apply 100V _{DC} for 1 minute
Endurance	$\Delta R \pm 0.2\%$	MIL-STD-202 Method 108 70 \pm 2°C, RCWV for 1000 hrs with 1.5 hrs "ON" and 0.5 hrs "OFF"
Operational Life	$\Delta R \pm 0.2\%$	MIL-STD-202 Method 108 Condition D Steady State T _A =125°C at derated power. Measurement at 24 \pm 4 hours after test conclusion.
Biased Humidity	$\Delta R \pm 0.1\%$	MIL-STD-202 Method 103 1000 hrs 85°C/85%RH 10% of operating power.
High Temperature Exposure	$\Delta R \pm 0.2\%$	MIL-STD-202 Method 108 at +155°C for 1000 hrs
Temperature Cycling	$\Delta R \pm 0.1\%$	JESD22 Method JA-104 -55°C to +125°C, 1000 cycles
Bending Strength (Board Flex)	$\Delta R \pm 0.1\%$	JIS-C-5201-1 4.33 Bending once for 60 seconds Bending displacement: 1020 1225 sizes: 2 mm 0612 sizes: 3 mm
Solderability	95% min. coverage	JIS-C-5201-1 4.17 IEC-60115-1 4.17 245 \pm 5°C for 3 seconds
Resistance to Soldering Heat	$\Delta R \pm 0.05\%$	JIS-C-5201-1 4.18 IEC-60115-1 4.18 260 \pm 5°C for 10 seconds
Terminal strength	No broken	AEC-Q200-006 Force of 1.8kg for 60 seconds.
Mechanical Shock	$\Delta R \pm 0.1\%$	MIL-STD-202 Method 213 Wave Form: Tolerance for half sine shock pulse. Peak value is 100g's. Normal duration (D) is 6.
Vibration	$\Delta R \pm 0.1\%$	MIL-STD-202 Method 204 5 g's for 20 min., 12 cycles each of 3 orientations, 10-2000 Hz
ESD	$\Delta R \pm 0.5\%$	AEC-Q200-002 Human body model 0612、1020、1225 2KV
Resistance to solvents	Marking Unsmearred	MIL-STD-202 Method 215 Add Aqueous wash chemical - OKEM Clean or equivalent. Do not use banned solvents.
Sulfur Test	$\Delta R \pm 1\%$	ASTM-B-809-95 Modified 105 \pm 2 °C no power rating for 1000 hrs.
Flammability	No ignition of the tissue paper or scorching or the pinewood board	UL-94 V-0 or V-1 are acceptable. Electrical test not required.

RCWV(Rated continuous working voltage)= $\sqrt{P \cdot R}$ or Max. Operating voltage whichever is lower

■ Storage Temperature: 15~28°C; Humidity < 80%RH

■ Shelf Life: 2 years from production date.

■Soldering Condition(IPC/JEDEC J-STD-020)

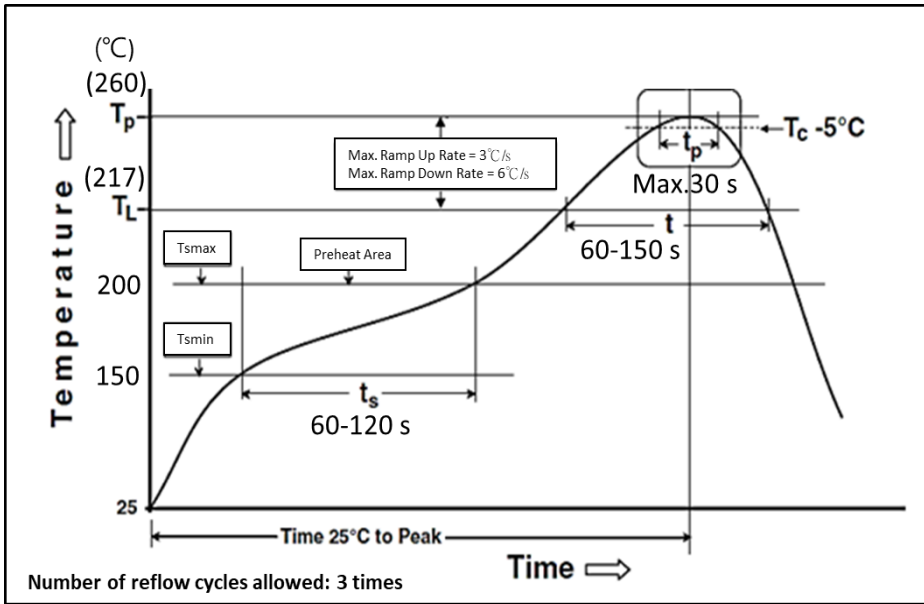

Reflow Profiles	
Profile Feature	Pb-Free Assembly
Preheat	
Min. Temperature (T _{min})	150 °C
Max Temperature (T _{max})	200 °C
Preheating time (t _s) from (T _{min} to T _{max})	60-120 seconds
Ramp-up rate (T _L to T _p)	3 °C/second max.
Liquidous temperature (T _L)	217 °C
Time (t _L) maintained above T _L	60-150 seconds
Min. Peak temperature (T _p min)	235°C
Max. Peak temperature (T _p max)	260°C
Time (t _p) within 5 °C of the specified classification temperature (T _c)	30 seconds max.
Ramp-down rate (T _p to T _L)	6 °C/second max.
Time 25 °C to peak temperature	8 minutes max.

【ARW..A Series】

Automotive Grade Thin Film Precision Chip Resistor(Wide Terminal)



■ Marking

0612~1225 4digit marking

Example

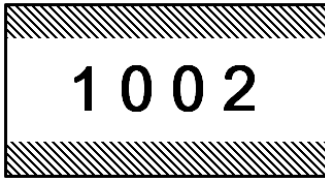

Resistance	4.7Ω	2.2KΩ	10KΩ	49.9KΩ	100KΩ
marking	4R70	2201	1002	4992	1003

■ Packaging

Packing Quantity & Reel Specifications

Unit :mm

Type	∅A	∅B	∅C	W	T	Paper Tape (EA)	Emboss Plastic Tape (EA)
ARW62	178.0±1.0	60.0+1.0	13.5±0.7	9.5±1.0	11.5±1.0	5,000	-
ARW20	178.0±1.0	60.0+1.0	13.5±0.7	13.5±1.0	15.5±1.0	-	4,000
ARW25	178.0±1.0	60.0+1.0	13.5±0.7	13.5±1.0	15.5±1.0	-	4,000

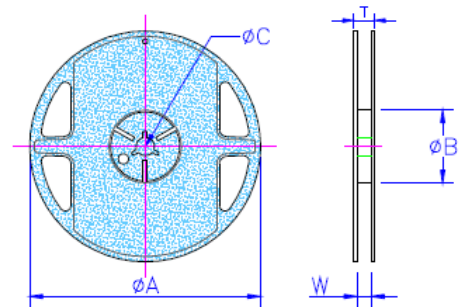

Paper Tape Specifications

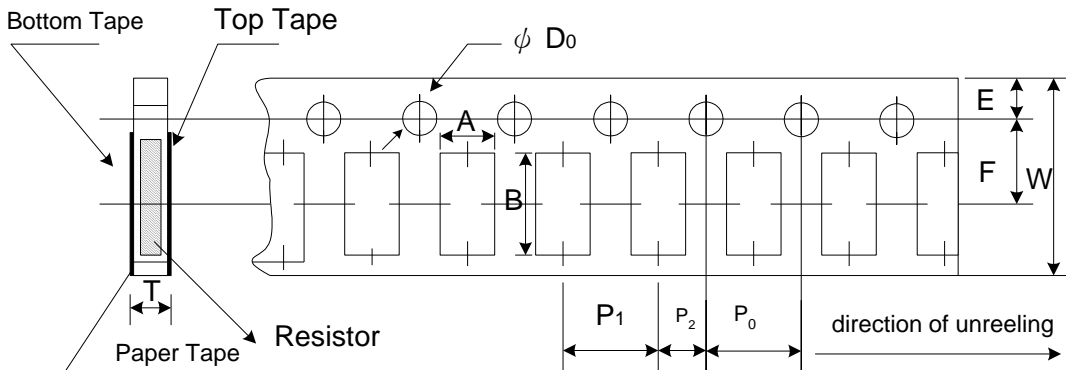

Unit: mm

Type	A	B	W	E	F	P ₀	P ₁	P ₂	∅D ₀	T
ARW62	2.00±0.05	3.55±0.05	8.00±0.10	1.75±0.05	3.5±0.05	4.00±0.10	4.00±0.10	2.00±0.05	1.55±0.05	0.75±0.05

- Peel force of top cover tape
- The peel speed shall be about 300mm/min±5%
- The peel force of top cover tape shall be between 8gf to 60gf

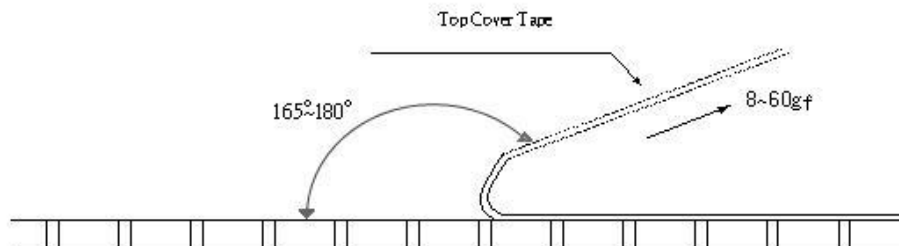

Emboss Plastic Tape Specifications

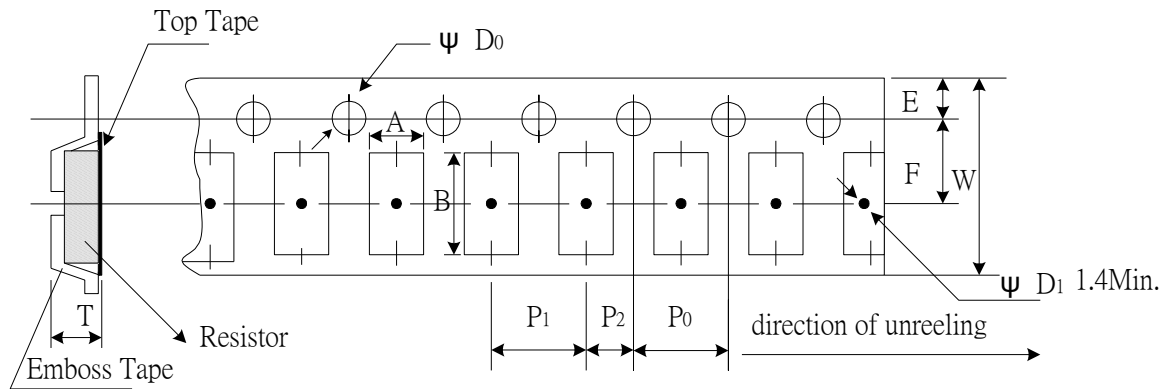

Unit: mm

Type	A	B	W	E	F	P ₀	P ₁	P ₂	$\varnothing D_0$	T
ARW20	2.85±0.10	5.45±0.10	12.0±0.10	1.75±0.10	5.5±0.05	4.00±0.05	4.00±0.10	2.00±0.05	1.50+0.10	1.00±0.20
ARW25	3.40±0.10	6.65±0.10	12.0±0.10	1.75±0.10	5.5±0.05	4.00±0.05	4.00±0.10	2.00±0.05	1.50+0.10	1.00±0.20

- Peel force of top cover tape
- The peel speed shall be about 300mm/min±5%
- The peel force of top cover tape shall be between 20gf to 80gf

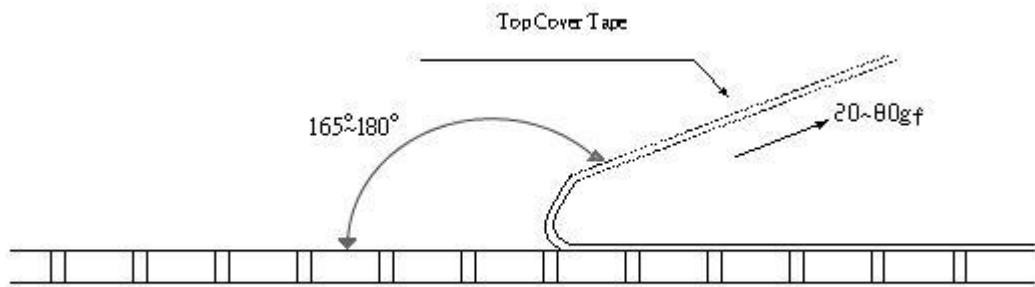

Recommend Land Pattern

Unit: mm

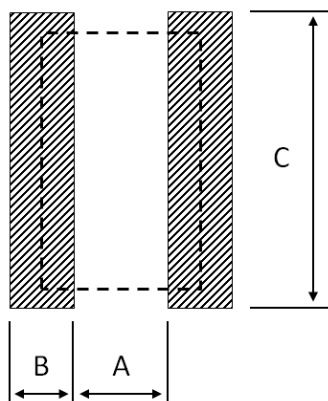

Type	A	B	C
ARW62	0.60	1.00	3.20±0.2
ARW20	1.00	1.20	5.00±0.2
ARW25	1.80	2.00	6.50±0.2

【ARW..A Series】

Automotive Grade Thin Film Precision Chip Resistor(Wide Terminal)



REVISION HISTORY

REVISION	DATE	CHANGE NOTIFICATION	DESCRIPTION
Version A	Mar.14.2024	-	- Correct the scheme.
Version A1	Jul 01 ,2024	-	- Modify the description in Features from "AEC-Q200 Compliance" to "AEC-Q200 Qualified".